

ADVANCED TECHNOLOGIES

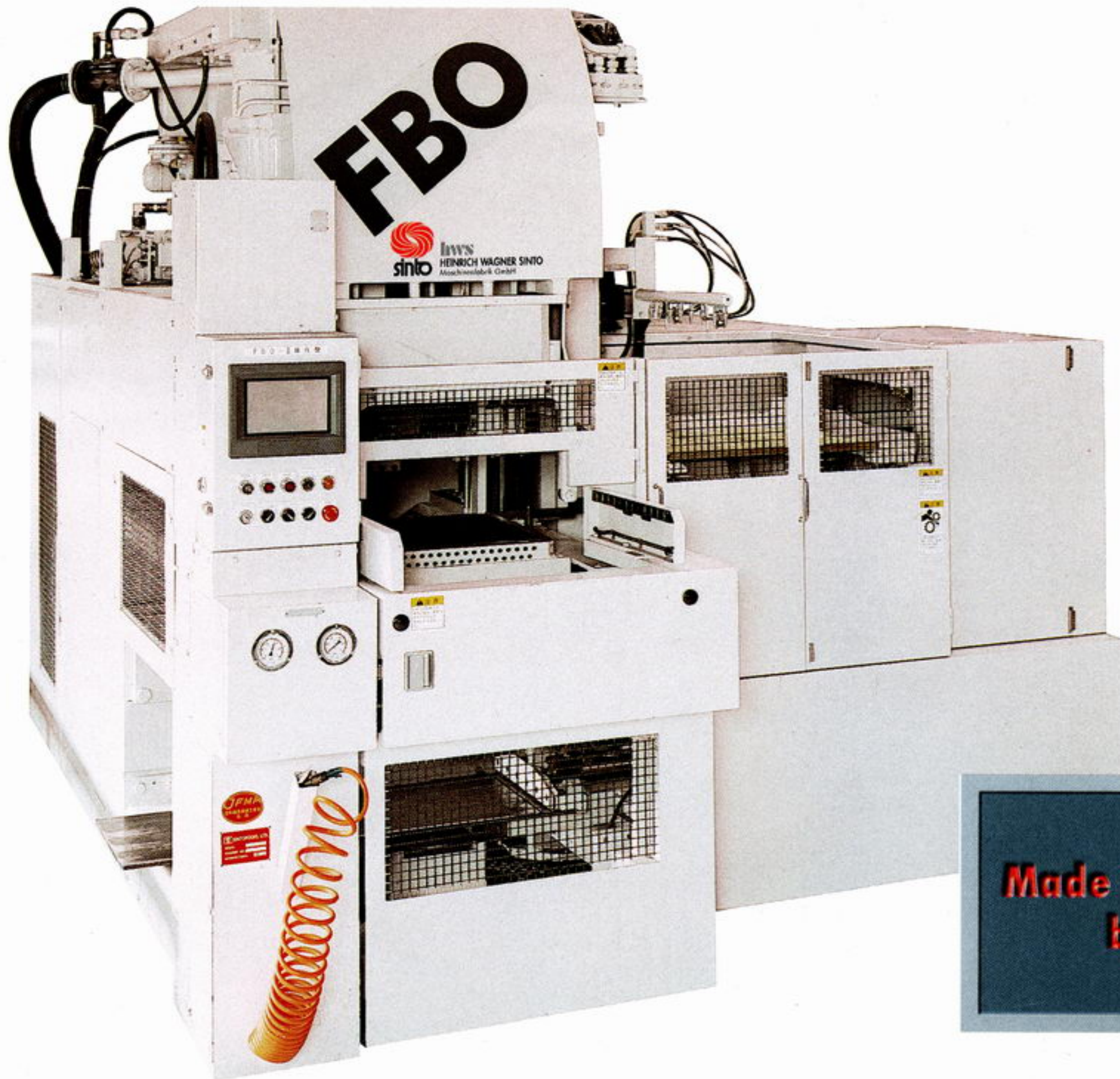

Made in Germany
by hws

FBO – FBO FLASKLESS MOULDING LINES

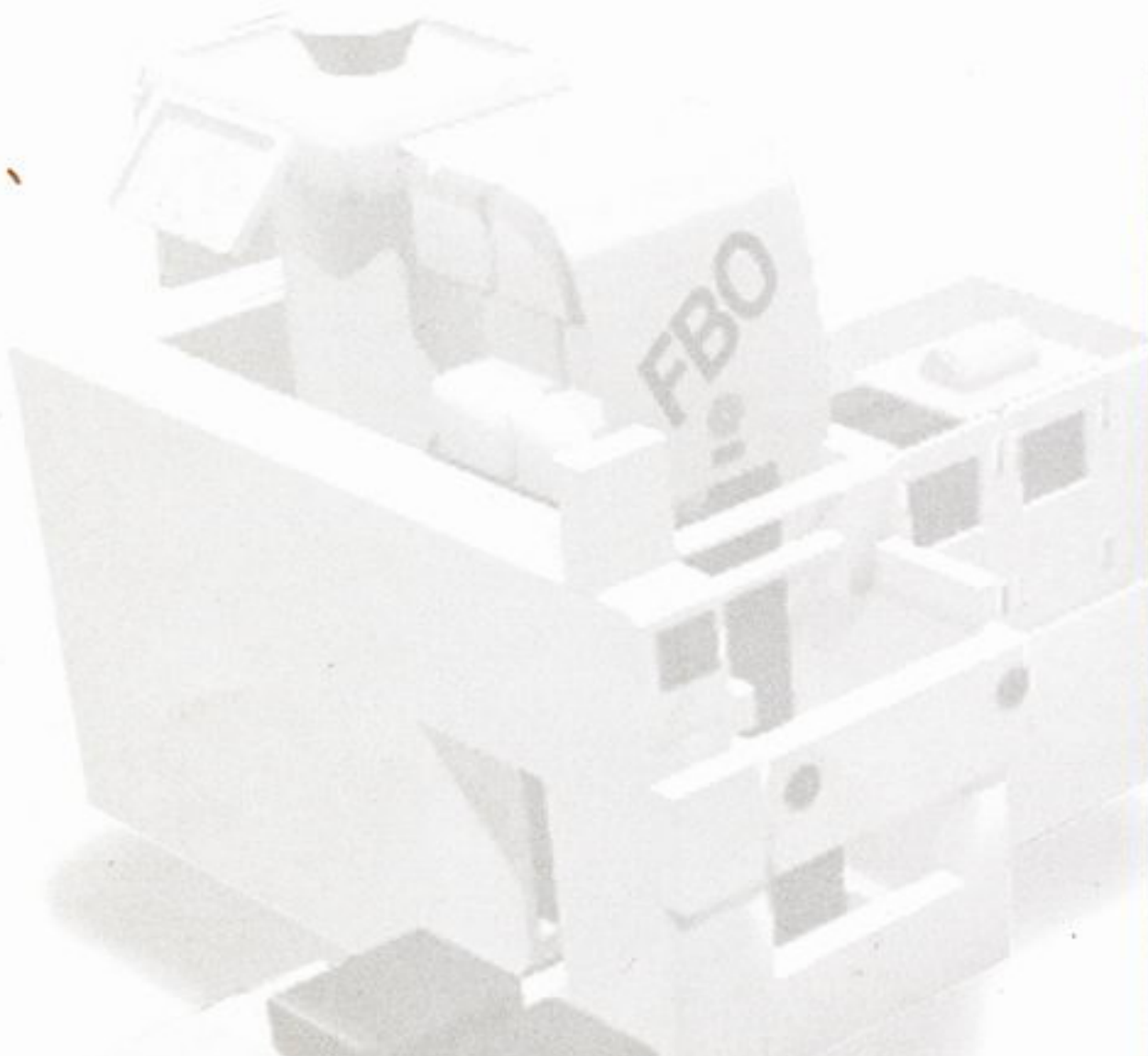

hws
HEINRICH WAGNER SINTO
Maschinenfabrik GmbH

FBO range overview

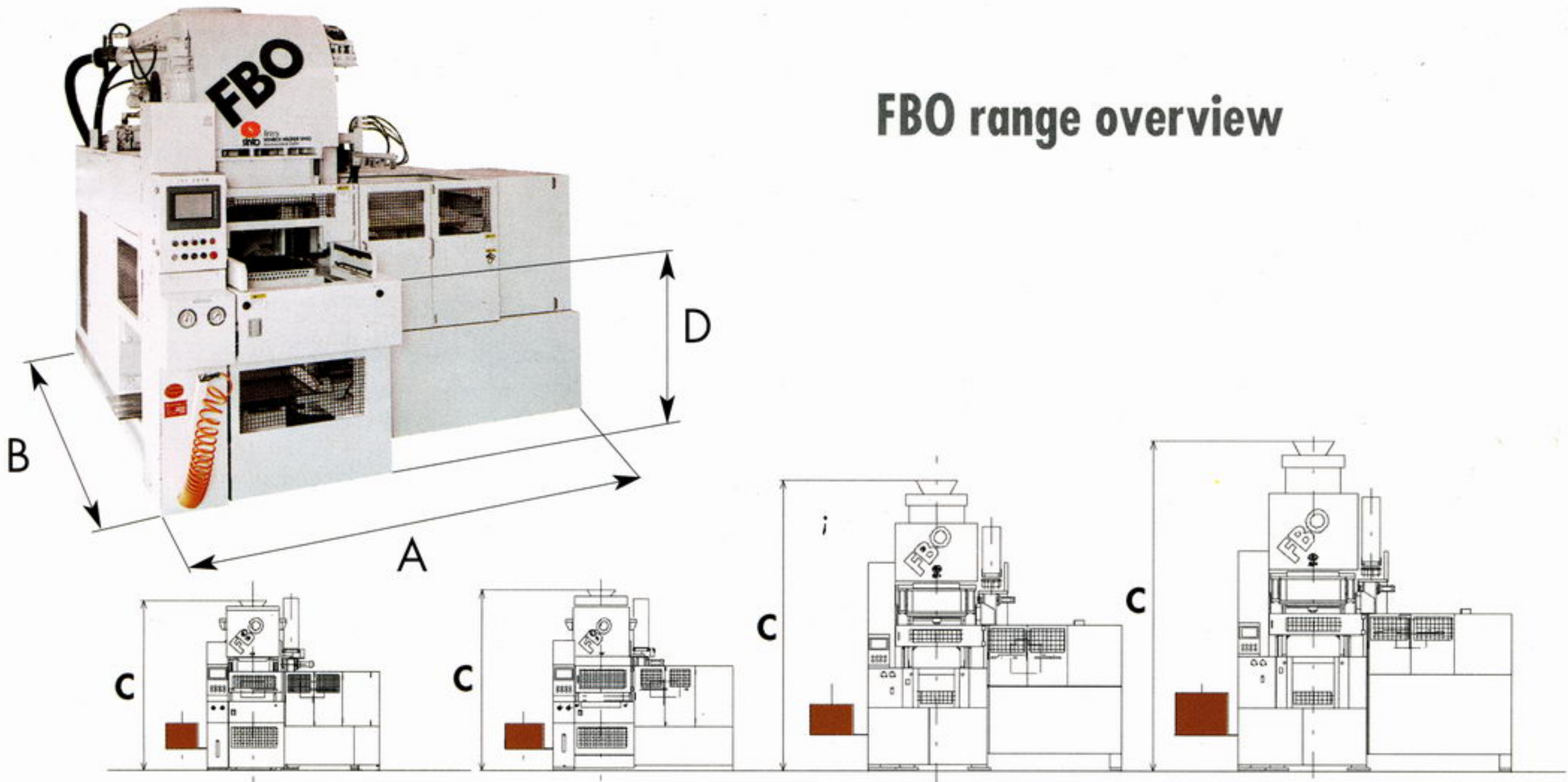

FBO-II

FBO-III

FBO-IV

FBO-V

All FBO moulding machines are available in either left hand or right hand operation.

Model		FBO II	FBO III		FBO IV	FBO V
			A	S		
Mould compaction		Sand blast and hydraulic pressing				
Mould package size B x L (mm)		Standard 500 x 400	Standard 600 x 500		Standard 700 x 600	Standard 900 x 700
		(Further mould sizes are available)				
Mould height (mm)		130 – 200	130 – 200		180 – 250	250 – 300
Dimensions (mm)	A	2890	3185		4225	4542
	B	3515	3630	3795	5035	5770
	C	2810	2987	3185	4477	5100
	D	1140	1140		1470	1810
Moulding speed, without core insertion (secs per mould)		24	30	21	36	45
Output approx. moulds/hour		150	120	170	100	80
Compression pressure N/cm ²		max. 100				
Compressed air requirement Nm ³ /mould		1	1.2		2.5	3.5
Power required kW		15	15	30	30	52
Additional equipment		Pressure plate heating				
Technical details subject to variation.						



hws
HEINRICH WAGNER SINTO
Maschinenfabrik GmbH

Bahnhofstraße 101 • D-57334 Bad Laasphe
Phone +49 (0) 27 52/9 07-0 • Fax +49 (0) 27 52/9 07-2 80
e-mail: info@wagner-sinto.de • Internet: www.wagner-sinto.de